

F *fantini*®

SVC-70-S



World Leader in Chain Saw Machines



- Taglio verticale primario a secco, senza fori
- Primary Vertical dry cuts, without any hole drilling

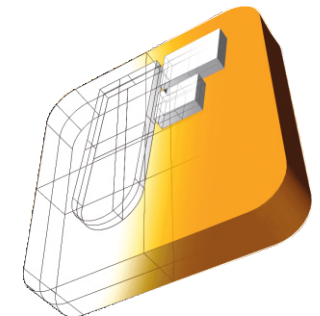

World Leader in Chain Saw Machines



- Assetto da trasporto per movimentazione automatica (Carro cingolato)
- Transport setting for automatic movement (tracks)

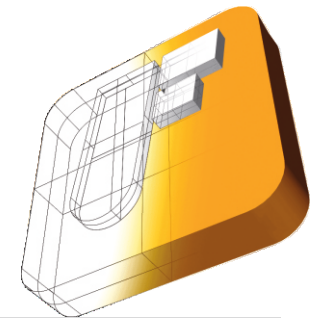

World Leader in Chain Saw Machines



Nuovo binario orizzontale (corsa da 2 o 4 m.)

New horizontal rail with variable run (from 2 m. to 4 m.)



Nuovi stabilizzatori brandeggiabili ausiliari per lavoro su piano inclinato.

New auxiliary stabilizers with variable arc rotation setting to work on inclined slopes.

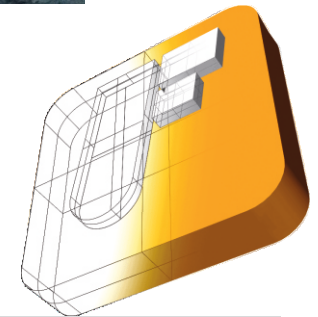

World Leader in Chain Saw Machines



- Tagli secondari.
- Secondary cuts.

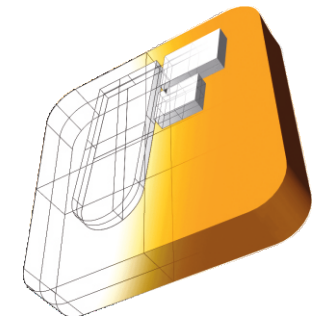

World Leader in Chain Saw Machines



Pannello elettrico in acciaio inox con elevato grado di resistenza alla corrosione e IP 65. PLC per controllare e lanciare tutte le sessioni di lavoro della macchina.

Electric Box in INOX steel with high resistance to corrosion and IP65. PLC to control and command all the working sessions of the machine.



Ampio display con interfaccia “user-friendly” per il controllo e la diagnostica della macchina in modo semplice ed elegante.

- Visualizzazione dei parametri attivi
- Parametri di lavoro
- Informazioni di taglio
- Contatore (parziali e totali)
- Reportistica allarmi
- Settaggio del taglio automatico

Wide display with “user friendly” interface to check and diagnostic of the machine simple and elegant.

- Visualize active parameters
- Working parameters
- Cutting information
- Hour counter (partial and total)
- Alarm report
- Automatic cut setting



La segatrice è totalmente controllata da un radio-comando per assicurare all'operatore di seguire tutte le operazioni della macchina da una distanza di sicurezza.

The machine is totally controlled by a radio remote control to allow a safety distance management by the operator.



World Leader in Chain Saw Machines



- Nuovi fari alogeni per consentire il lavoro notturno.
- Night time work with new halogen lights

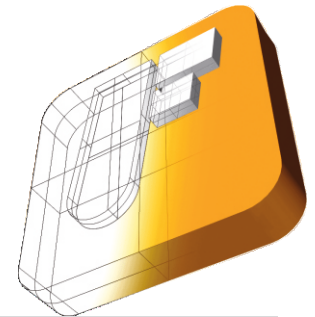
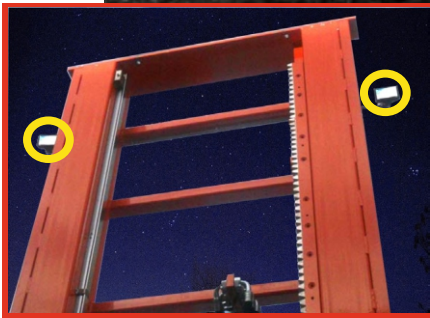

World Leader in Chain Saw Machines



- Taglio su piano inclinato.
- Inclined surface cut.

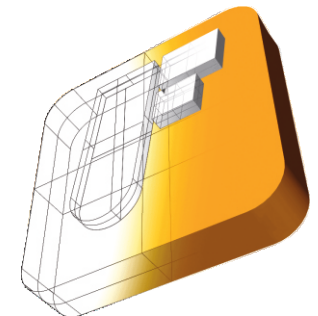

World Leader in Chain Saw Machines



- Riquadratura di grandi blocchi informi.
- Dressing of big unshaped blocks.

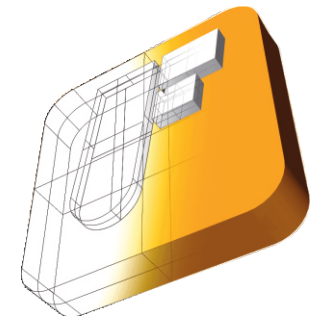

World Leader in Chain Saw Machines

RIBALTAMENTO PUNTONE	SCREW DOWN JACK TILTING
ROTAZIONE CATENA	CHAIN ROTATION
TRASLAZIONE CARRELLO VERTICALE	VERTICAL TROLLEY TRANSLATION
STABILIZZATORI POSTERIORI	REAR STABILIZERS
ROTAZIONE BRACCIO	ARM ROTATION
TRASLAZIONE CARRELLO ORIZZONTALE	HORIZONTAL TROLLEY TRANSLATION
STABILIZZATORI ANTERIORI	FRONT STABILIZERS
STABILIZZATORI BRANDEGGIANTI	STABILIZERS ARC ROTATION
ROTAZIONE CINGOLI	TRACKS ROTATION
MARCIA CINGOLI	TRACKS START

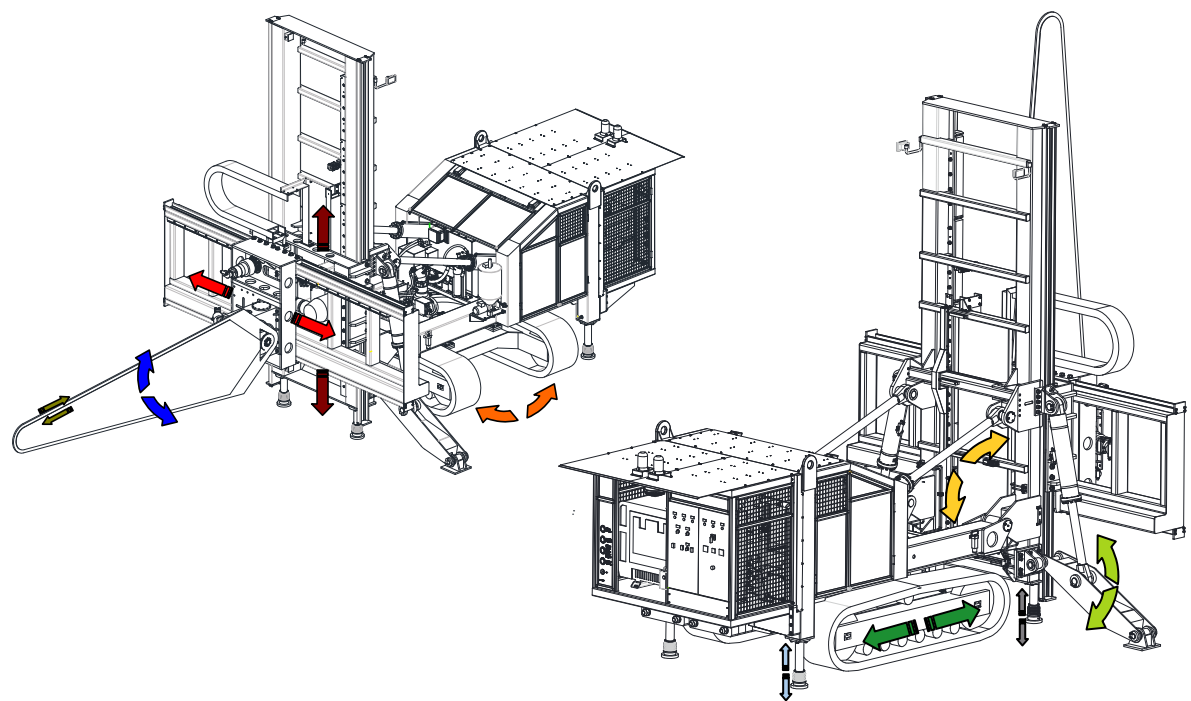

World Leader in Chain Saw Machines

DIMENSIONI MACCHINA MACHINE DIMENSION

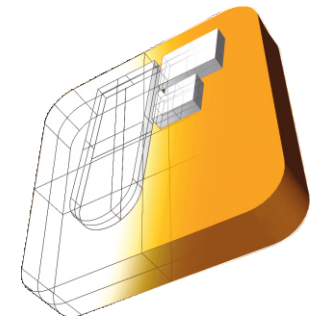
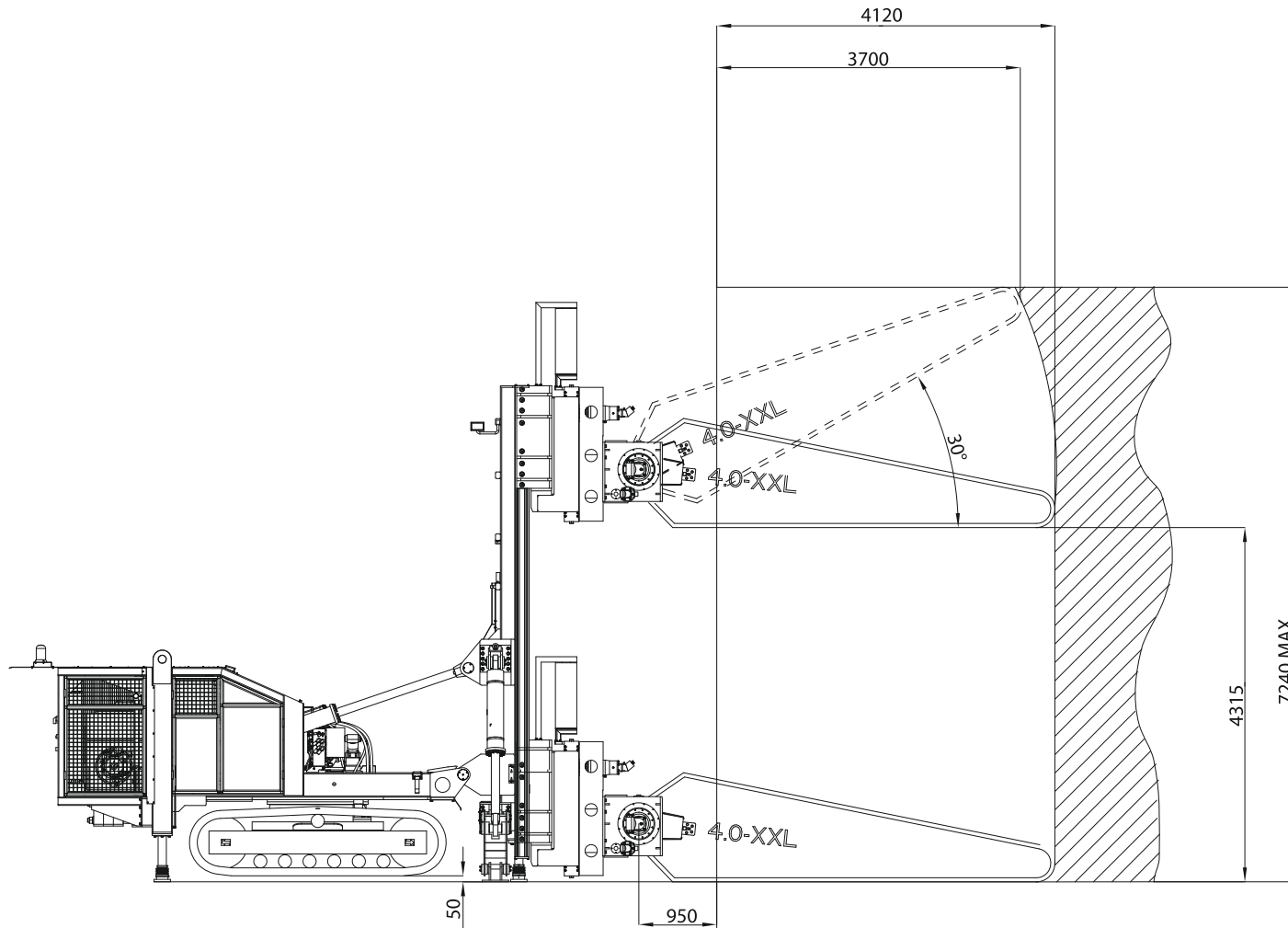

World Leader in Chain Saw Machines

DIMENSIONI MACCHINA
MACHINE DIMENSION

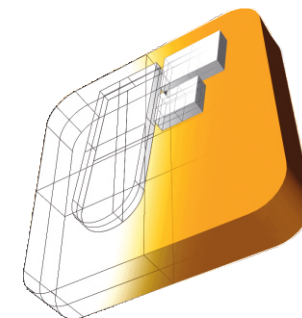
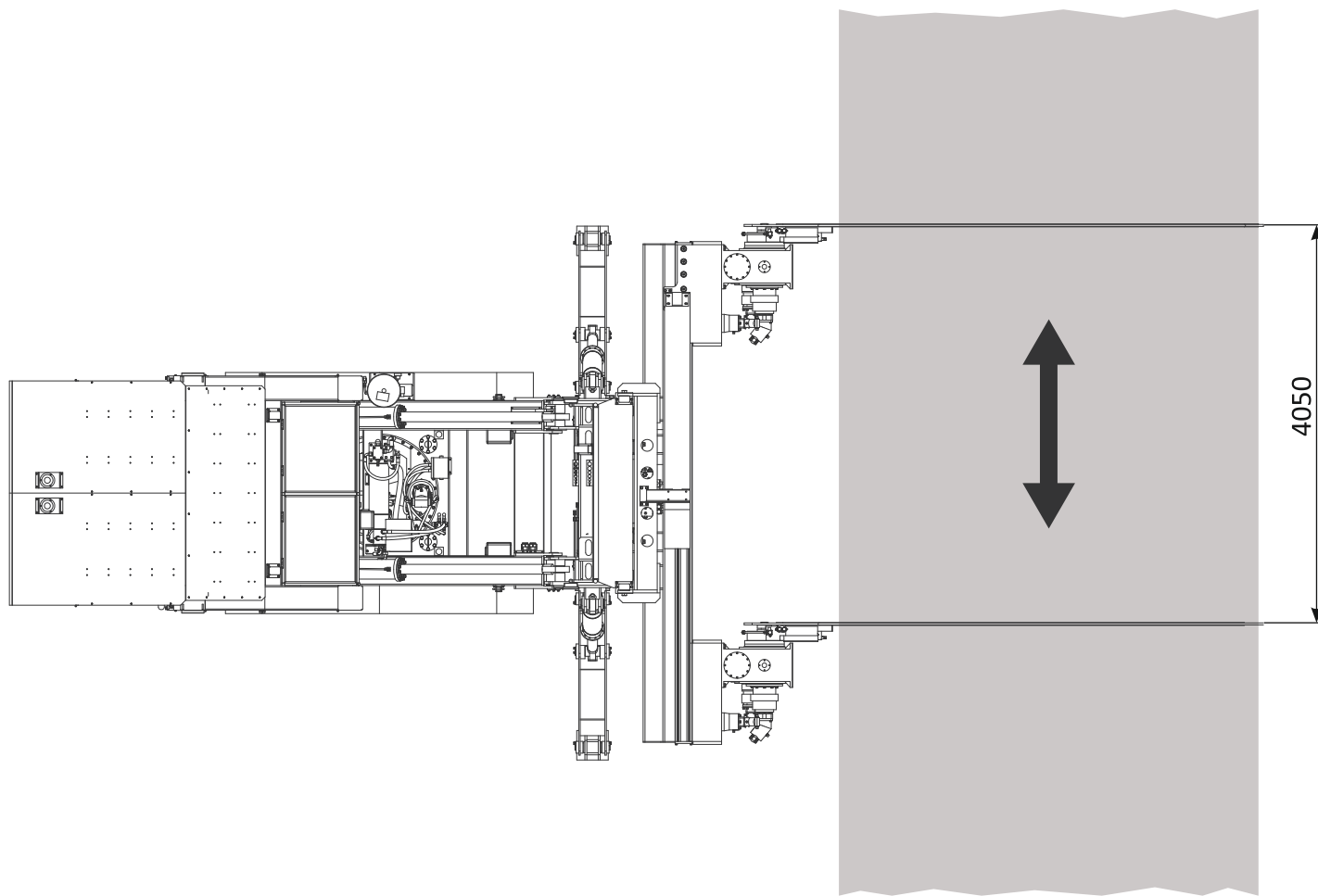

World Leader in Chain Saw Machines

PERSONALIZZAZIONI CUSTOMIZATIONS

TESTA/HEAD:

70 RA



(Taglio utile fino a /Cutting depth up to: 4,0 m)

70 SUP-H



(Taglio utile fino a /Cutting depth up to: 6,2 m)

STABILIZZATORI BRANDEGGIANTI AUSILIARI/ AUXILIARY ARC ROTATING STABILIZERS:

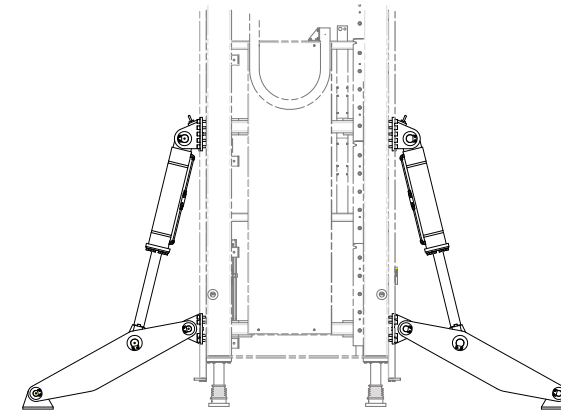

BINARIO ORIZZONTALE/ HORIZONTAL RAIL:

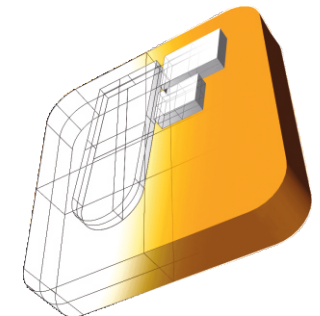
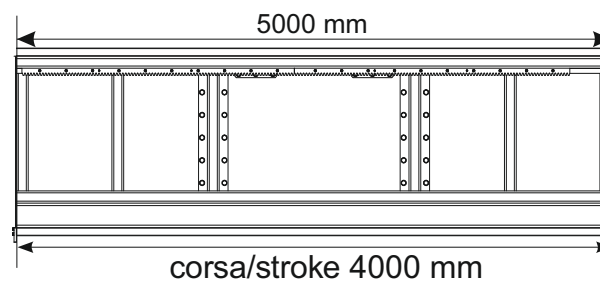
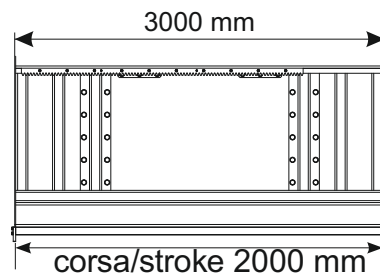

World Leader in Chain Saw Machines



- Taglio a secco - no acqua
- Dry cut - no water at all

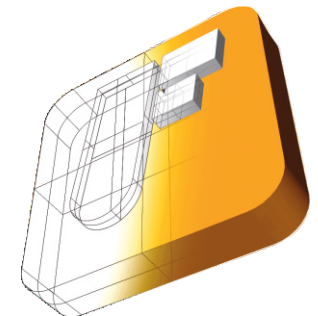

World Leader in Chain Saw Machines



- Niente più fori
- No more drilling

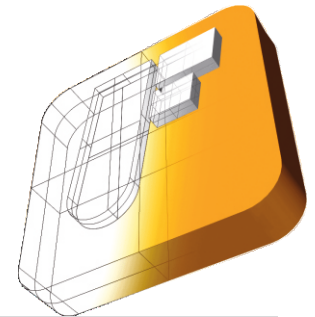

World Leader in Chain Saw Machines



- Taglio secondario sulla bancata
- Secondary cut on the bench



World Leader in Chain Saw Machines



■ Taglio verticale primario

■ Main vertical cut

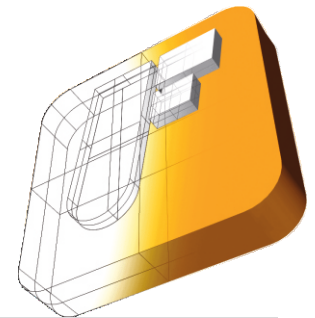

World Leader in Chain Saw Machines



- Ciclo di taglio completo fino ad ottenere blocchi dimensionali
- Complete working cycle to obtain sized blocks

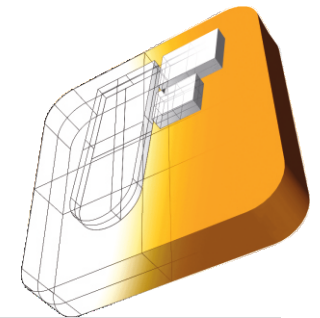

World Leader in Chain Saw Machines



- Apertura di canali frontali
- Opening of front channels

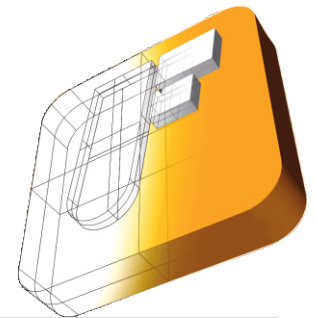

World Leader in Chain Saw Machines



Fantini Sud S.p.A. - Strada provinciale 12, n° 52
03012 Anagni (Fr) - Italy
Tel: +39.0775.77.49.1 - Fax: 39.0775.76.96.40
www.fantinispa.it - e-mail: info@fantinispa.it