

F *fantini*®

70 RA/P-TA



World Leader in Chain Saw Machines

PANNELLO OPERATORE

Control-panel

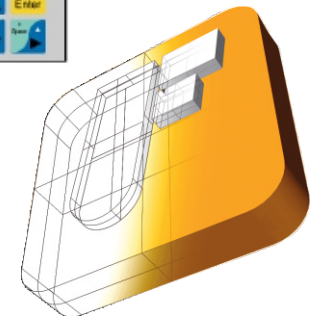
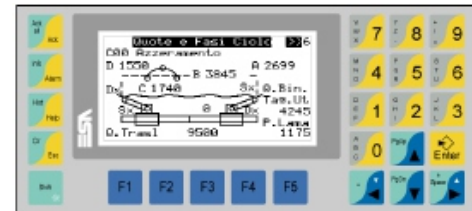

World Leader in Chain Saw Machines



SENSORI CONTROLLO PRESENZA BINARIO

Su entrambi i lati del carrello c'è un proximity per controllare la posizione della macchina lungo il binario. Nel momento in cui il proximity non rileva più il binario, si attiva il segnale di fine corsa che ferma tutti i movimenti della macchina, accende il lampeggiante rosso e visualizza un messaggio sul display.

SENSORS RAIL CONTROL

On both sides of the carriage there is a proximity sensor for monitoring the machine's position along the rail. As soon as the proximity sensor doesn't detect the rail anymore, a stop signal gets activated, that stops all movements of the machine, turns on a red light flashing light and displays a message on the operator's control panel.

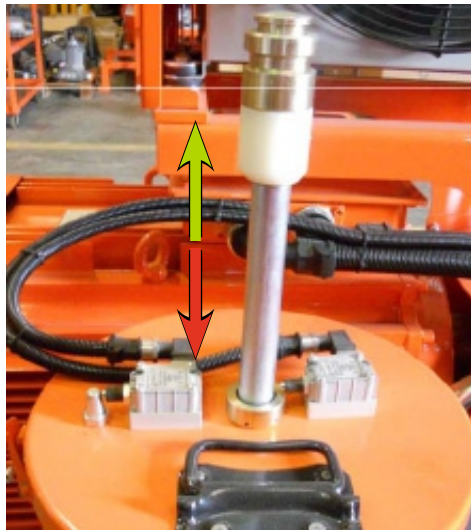

SENSORE CONTROLLO LIVELLO MINIMO GRASSO

In caso di mancanza di grasso si accende un lampeggiante rosso e viene visualizzato un messaggio di allarme.

GREASE MINIMUM LEVEL SENSOR

If there is no grease a red flashing light turns on and an alarm is displayed.

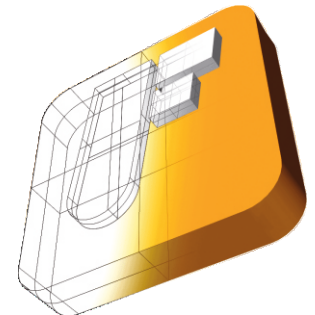

SENSORI CONTROLLO TRASLAZIONE CARRELLO E ROTAZIONE BRACCIO

La funzione di taglio automatico è gestito da un PLC che elabora i dati sulla posizione del carrello lungo il binario e l'inclinazione del braccio.

SENSORS CONTROL ARM ROTATION AND CARRIAGE TRANSLATION

The automatic cut mode is controlled by a PLC that reads the data about the position of the carriage along the rail and the blade's angle.

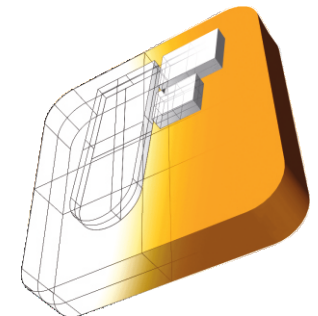
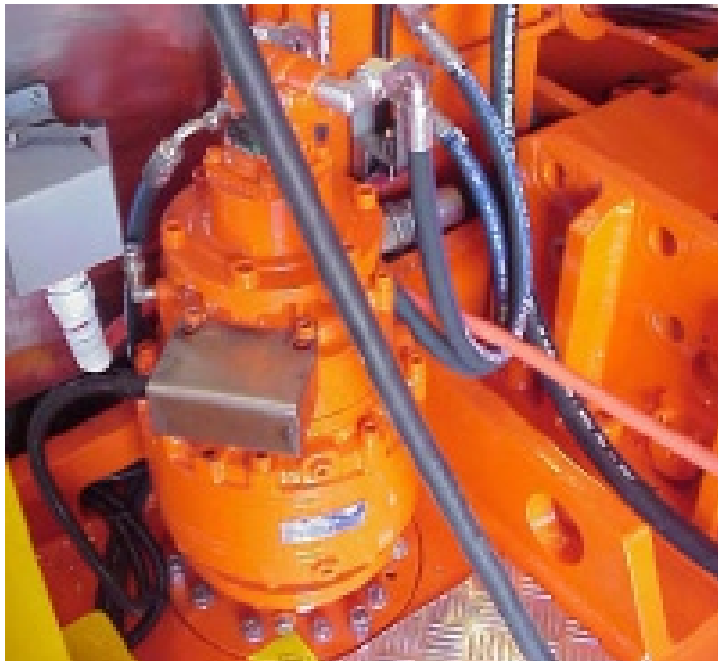

World Leader in Chain Saw Machines

ENTRATA, TRASLAZIONE (TAGLIO) ED USCITA DEL BRACCIO AUTOMATICI
COMPUTER-CONTROLLED ENTRY, TRANSLATION (CUT) AND EXIT OF THE BLADE

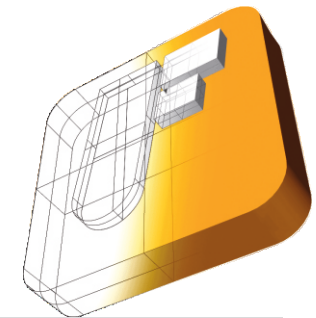

World Leader in Chain Saw Machines

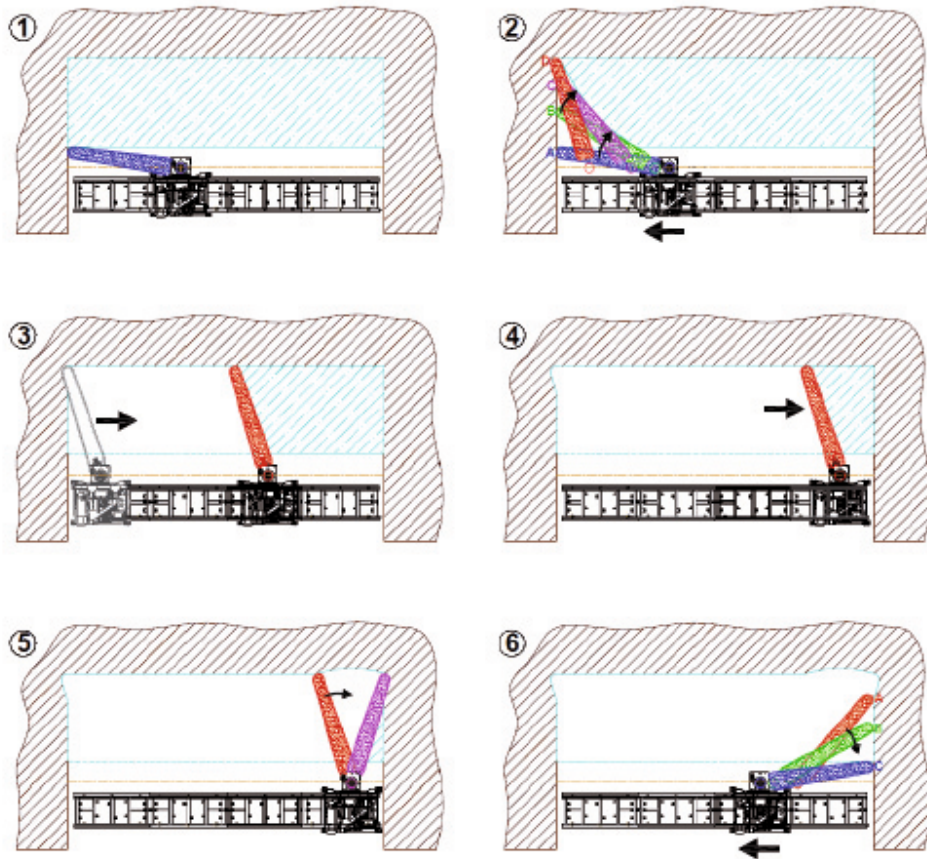

CICLO AUTOMATICO DI TAGLIO

COMPUTER-CONTROLLED
CUTTING PROCESS

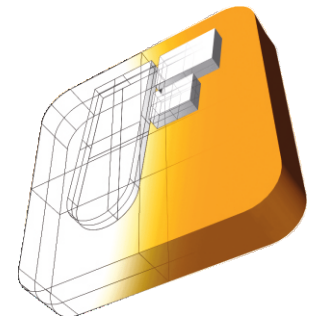

World Leader in Chain Saw Machines



**ASPIRATORE
OPZIONALE**
OPTIONAL DUST
ASPIRATOR

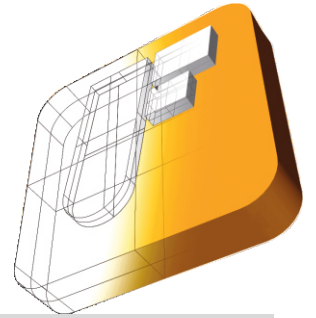
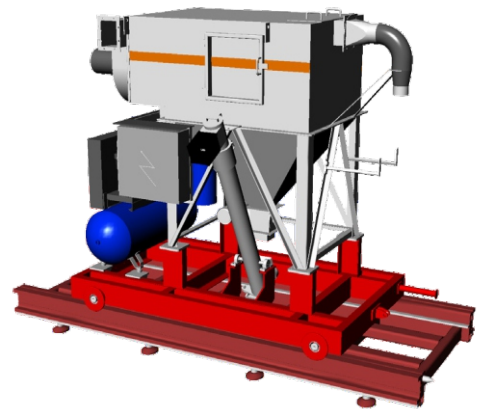

World Leader in Chain Saw Machines



Fantini Sud S.p.A. - Strada provinciale 12, n° 52
03012 Anagni (Fr) - Italy
Tel: +39.0775.77.49.1 - Fax: 39.0775.76.96.40
www.fantinispa.it - e-mail: info@fantinispa.it